

WMAP MI D WATER METER

Bulk Meters

+ WMAP MIO is the latest range of Woltmann meters by RBM. WMAP MIO meters feature a dry dia I, an axial helix and a removable mechanism.

This new range of water meters has been developed in order to meet the strict requirements of the Directive 2004/22/EC on measuring instruments and European Standard EN 14154. WMAP MIO meters are manufactured with materials formulated for long-term metrological performance. The rugged design ensures reliable operation.

WMAP MIO meters are designed for remote communication: they can be retrofitted with a pulse emitter or a radio module maintaining the mechanical and metrological features and without affecting readability.



PRODUCTION RANGE

Code	Size	
	mm	inches
1093.09.02 2580.09.00	50	2"
1093.10.02 2580.10.00	65	2" 1/2
1093.11.02 2580.11.00	80	3"
1093.13.02 2580.13.00	100	4"
1093.14.02 2580.14.00	125	5"
1093.15.02 2580.15.00	150	6"
1093.17.02 2580.17.00	200	8"

DESCRIPTION

WMAP MID is an axial helix (the axis of the helix is coaxial to the axis of the pipe) **Woltmann meter with removable mechanism**. The magnetically driven register operates in a dry compartment and only the helix is submerged in water. Readability is ensured by the **tempered mineral glass lens**: its flat and smooth surface, unlike plastic lenses, is scratch-resistant and does not turn opaque.

WMAP MID meters are pre-equipped for two pulse outputs as a standard. The pulse emitter can be retrofitted maintaining both the meter functionality and design.

WMAP MID meters can be installed both in horizontal and vertical

position. Performance is unaffected by the installation conditions and the water characteristics.

WMAP MID water meters comply with Directive 2004/22/EC (Annex MI-001) and have undergone conformity assessment procedure B+D. The maximum measuring range Q_3/Q_1 (R) certified is 100. Lower measuring ranges are also available (R80, R50, etc.).

WMAP MID water meters are certified for use with potable water in accordance with Italian (D.M. 6 April 2004 no. 174) and international regulations.

SPECIFICATIONS

Tempered mineral glass lens of adequate thickness

The counter is housed in a dry compartment which has no contact with the water ensuring continued readability

Straight reading on 7 numbered drums for cubic meters and 2 fractional dials for submultiples

The MID inscriptions are on a metallic label applied on a meter's flange

Metallic lockable lid

Pulsed meters maintain the metrological seal and are protected by a cover

No upstream (use of flow straighteners) and downstream straight pipe requirements

Hydraulic tests are carried out at three flow rates (Q_1 , Q_2 , Q_3) on 100% of the production. Our testing benches comply with the Standards ISO 4064/3 and ISO 4185 (EN 14154/3) and are approved by a European notified body

Cast iron flanged body; internal and external epoxy powder coating

Steel pivot, synthetic sapphire bearing

Internal mechanism made of anhygroscopic, anti-scaling and hard-wearing plastic materials

Maximum water temperature: 50 °C

Nominal pressure (PN): 10 or 16 bar



HYDRAULIC PERFORMANCE

Code		1093.09.02 2580.09.00	1093.10.02 2580.10.00	1093.11.02 2580.11.00	1093.13.02 2580.13.00	1093.14.02 2580.14.00	1093.15.02 2580.15.00	1093.17.02 2580.17.00
Size	mm	50	65	80	100	125	150	200
	inches	2"	2"1/2	3"	4"	5"	6"	8"
Module B no.					TCM 142/17-5473			
Module D no.					0119-SJ-A010-08			
Metrological class MID		H↑ ≤250 H→; V↑; V↓; inclined ≤160			H↑; V↑; inclined ≤250 H→; V↓ ≤125			

PERFORMANCE IN DIRECTIVE 2014/32/UE

Q₃	m ³ /h	40	63	100	160	160	250	400
Q₄	m ³ /h	50	78,8	125	200	200	312,5	500

R 100 (STANDARD)

Q₁	l/h	400	630	1000	1600	1600	2500	4000
Q₂	l/h	500	788	1250	2000	2000	3125	5000

R 250

Q₁	l/h	160	250	400	640	640	1000	1600
Q₂	l/h	260	400	640	1020	1020	1600	2560

TECHNICAL SPECIFICATIONS

Code		1093.09.02 2580.09.00	1093.10.02 2580.10.00	1093.11.02 2580.11.00	1093.13.02 2580.13.00	1093.14.02 2580.14.00	1093.15.02 2580.15.00	1093.17.02 2580.17.00	
Maximum permissible error between Q₁ and Q₂ (excluded)	-								± 5%
Maximum permissible error between Q₂ (included) and Q₄	-								±2 % with water temperature ≤ 30 °C ±3 % with water temperature > 30 °C
Temperature class	-								T50
Flow profile sensitivity classes	-								U0 – D0
Starting flow rate	l/h	125	190	320	450	700	1200	1800	
Pressure loss class (ΔP @ Q₃)		ΔP25	ΔP40	ΔP25	ΔP40	ΔP40	ΔP16	ΔP40	
Operating pressure	Bar	16	16	16	16	16	16	16	
Maximum registration	m ³	10.000.000	10.000.000	10.000.000	10.000.000	10.000.000	100.000.000	100.000.000	
Minimum registration	m ³	0.002	0.002	0.002	0.002	0.002	0.02	0.02	
Turbine revolutions/litre	-	1,08	1,02	0,39	0,32	0,40	0,25	0,15	
Weight	Kg	10,0	11,2	15,2	17,2	22,4	29,0	42,6	
Reed switch emitter pulse setup V max. ≤ 24V; I max. 0,1 A	l/imp.	10-1000	10-1000	10-1000	10-1000	10-1000	100-10000	100-10000	
Inductive emitter pulse setup V max. ≤ 24V; I max. 0,1 A	l/imp.	10	10	10	10	10	100	100	

DIMENSIONS

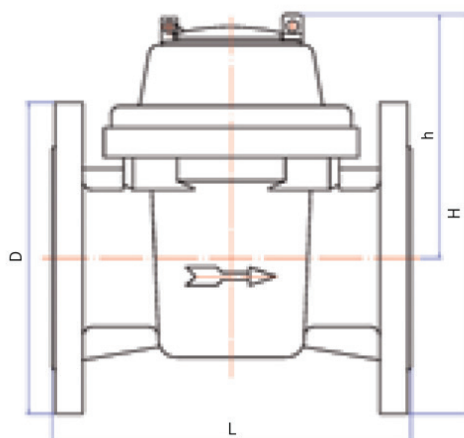

Code	Measure		L [mm]	H [mm]	h [mm]	D [mm]
	[mm]	[inches]				
1093.09.02 2580.09.00	50	2"	200	209	132	165
1093.10.02 2580.10.00	65	2"1/2	200	218	132	185
1093.11.02 2580.11.00	80	3"	225	249	154	200
1093.13.02 2580.13.00	100	4"	250	258	154	220
1093.14.02 2580.14.00	125	5"	250	271	154	250
1093.15.02 2580.15.00	150	6"	300	316	183	280
1093.17.02 2580.17.00	200	8"	350	345	183	340

Flange according to UNI EN 1092-1 standard (PN16)

FLUID DYNAMICS FEATURES

TYPICAL ERROR CURVE

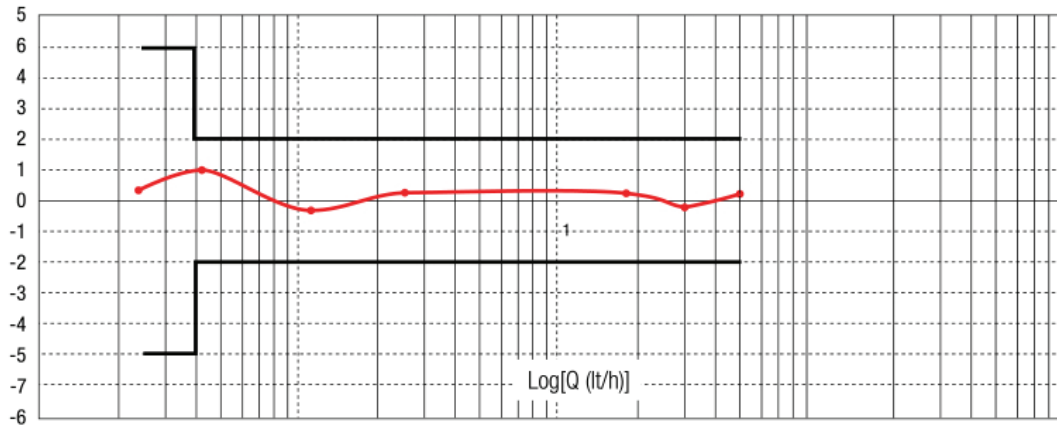

HEADLOSS DIAGRAM

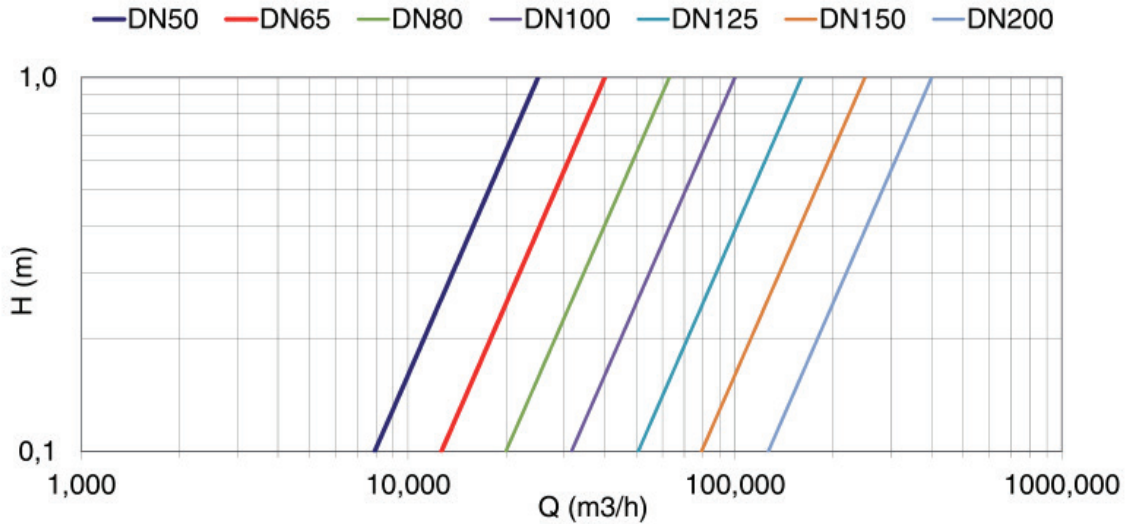

RBM spa reserves the right to improve and change the products described and relevant technical data at any moment and without prior notice. The information and images contained in this document are intended for information purposes only, are not binding and in any case do not exempt the user from strictly following the regulations in force and good practice standards.